

FILM PROJECTOR UNIT
(Machine Code: A846)

1. SPECIFICATIONS

Acceptable Film Types: Type: Positive film/Negative film
 Size: 35 mm - Approx. 140 x 210 mm
 Others: 45 x 60 mm, 60 x 60 mm,
 60 x 70 mm, 60 x 80 mm,
 60 x 90 mm, 4" x 5"
 Max: 142 x 210 mm or 5.6" x 8.2"
 Mount: Yes (Up to 5 frames can be set in the
 film holder.)
 Strip: Yes (A series of 6 frames can be
 set in the film holder.)

Focusing: Fixed/Manual
 Effective Film Area: 35 mm: Approx. 21.5 x 33.0 mm
 Other Sizes: Full Size
 Projection Ratio 35 mm: Approx. x 6
 Other Sizes: x 1
 Copy Image Size 35 mm mount: 120.8 x 192.7 mm
 35 mm strip: 129.3 x 198.6 mm
 Other Sizes: Full Size

All the reproduction features of the copier are available.

Power Source: 120 V 60 Hz, more than 0.9 A
 220 ~ 240 V 50/60 Hz, more than 0.5 A

Dimensions (W x D x H): Projector: 300 x 442 x 212 mm
 11.8" x 17.4" x 8.35"
 Mirror Unit: 298 x 232 x 50 mm
 11.73" x 9.13" x 1.97"

Weight: Projector: 10 kg, 22.1 lb
 Mirror unit: 5 kg, 11.1 lb

Remarks: The holder is required for installation.

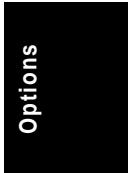

2. ELECTRICAL COMPONENT LAYOUT AND DESCRIPTIONS

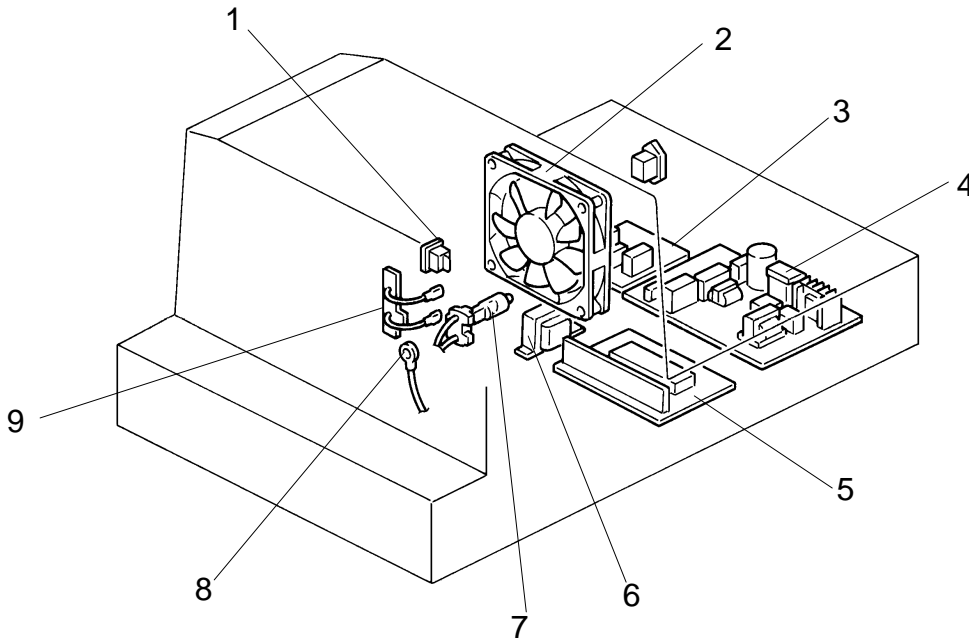

A718V500.PCX

Symbol	Name	Function	Index No.
PCB1	Projector Lamp Regulator	Supplies dc voltage to the projector lamp and lamp cooling fan.	4
PCB2	Projector Control Board	Controls the projector unit, communicating with the copier main board.	5
PCB3	Noise Filter Board (220—240V machine only)	Removes electrical noise.	3
M1	Lamp Cooling Fan	Blows air to the projector lamp section.	2
SW1	Projector Switch	Provides power to the projector unit.	1
L1	Projector Lamp	Applies light to the film for exposure.	7
TH1	Lamp Thermistor	Detects the temperature around the projector lamp to control the lamp cooling fan.	8
TF1	Lamp Thermofuse	Opens the projector lamp circuit if the projector lamp section overheats.	9
TR1	Transformer	Steps down the wall voltage to 17 ~ 18 V ac.	6

3. SECTIONAL DESCRIPTIONS

3.1 OVERVIEW

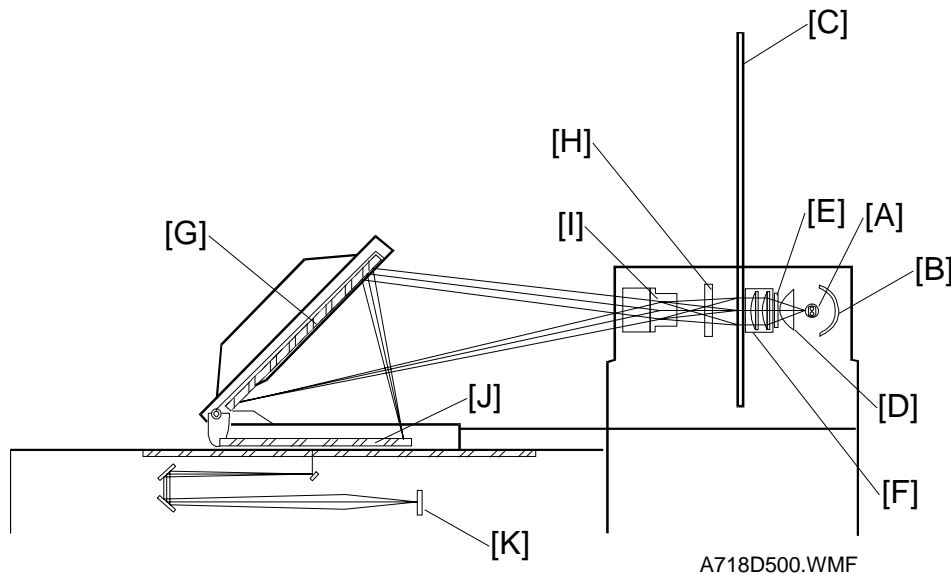

This film projector unit allows copying from the following kinds of films:

- 35 mm positive slides (both mount films and glass mount films)

- 35 mm negative or positive strip films

- Positive or negative films of a wide size

- (45 x 60/60 x 60/60 x 70/60 x 80/60 x 90 mm/4" x 5"/

- Maximum size of 142 x 210 mm or 5.6" x 8.2")

The light from the projector lamp [A] is reflected by the reflector [B] and reaches the film (35 mm) in the film/slide holder [C] through the non-spherical lens [D], heat filter [E], and condenser lenses [F]. The projected film image reaches the mirror [G] through the correction filter (positive or negative) [H] and projection lens [I]. Then the mirror reflects the image onto the exposure glass through the Fresnel lens [J]. The first scanner moves under the exposure glass to read the projected film image and the light of the image is converted to R/G/B electrical signals by the CCD [K].

The 35 mm film's image is enlarged about 6 times when projected onto the exposure glass.

For wide films, the first scanner reads the film placed on the exposure glass directly using the light from the projector lamp.

The lamp cooling fan turns on and off depending on the temperature of the projector lamp section detected by the lamp thermistor. It turns on at around 45°C and turns off at around 44°C.

3.2 SHADING

When the projector unit is selected, shading should be done after selecting the type of film. The shading should be done with a base film and the N-correction filter for the negative films and with the P-correction filter (without base film) for the positive films.

The N-correction filter corrects the color and intensity of the projected light. The P-correction filter corrects the light intensity of the projected light so that it becomes similar to that for the negative films.

When "Shading" is performed, the first scanner moves and stops under the mirror unit. Then AGC (Auto Gain Control) for the light intensity from the projector lamp is performed. Shading for black and white levels is also performed after the AGC.

This "Shading" should be performed whenever the type of film is changed or the mirror unit is moved.

3.3 MIRROR UNIT

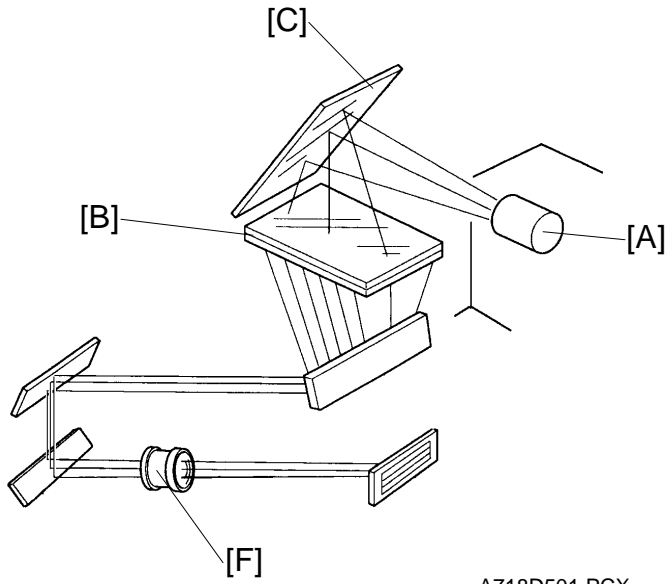

A718D501.PCX

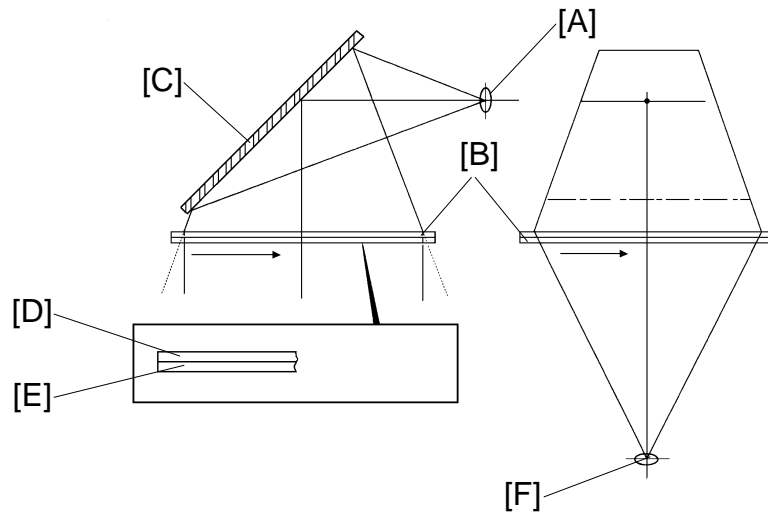

A718D502.PCX

The film image projected through the projection lens [A] is reflected to the Fresnel lens [B] by the mirror [C].

The Fresnel lens consists of two components, a circular-pitch Fresnel lens [D] and a parallel-pitch Fresnel lens [E]. The circular-pitch Fresnel lens changes divergent light to parallel light. The parallel-pitch Fresnel lens collects the light from the circular-pitch Fresnel lens in the main scan direction so that all the light reaches the color CCD lens [F].

The use of these two types of Fresnel lens makes the most of the light intensity from the projector lamp.

Options

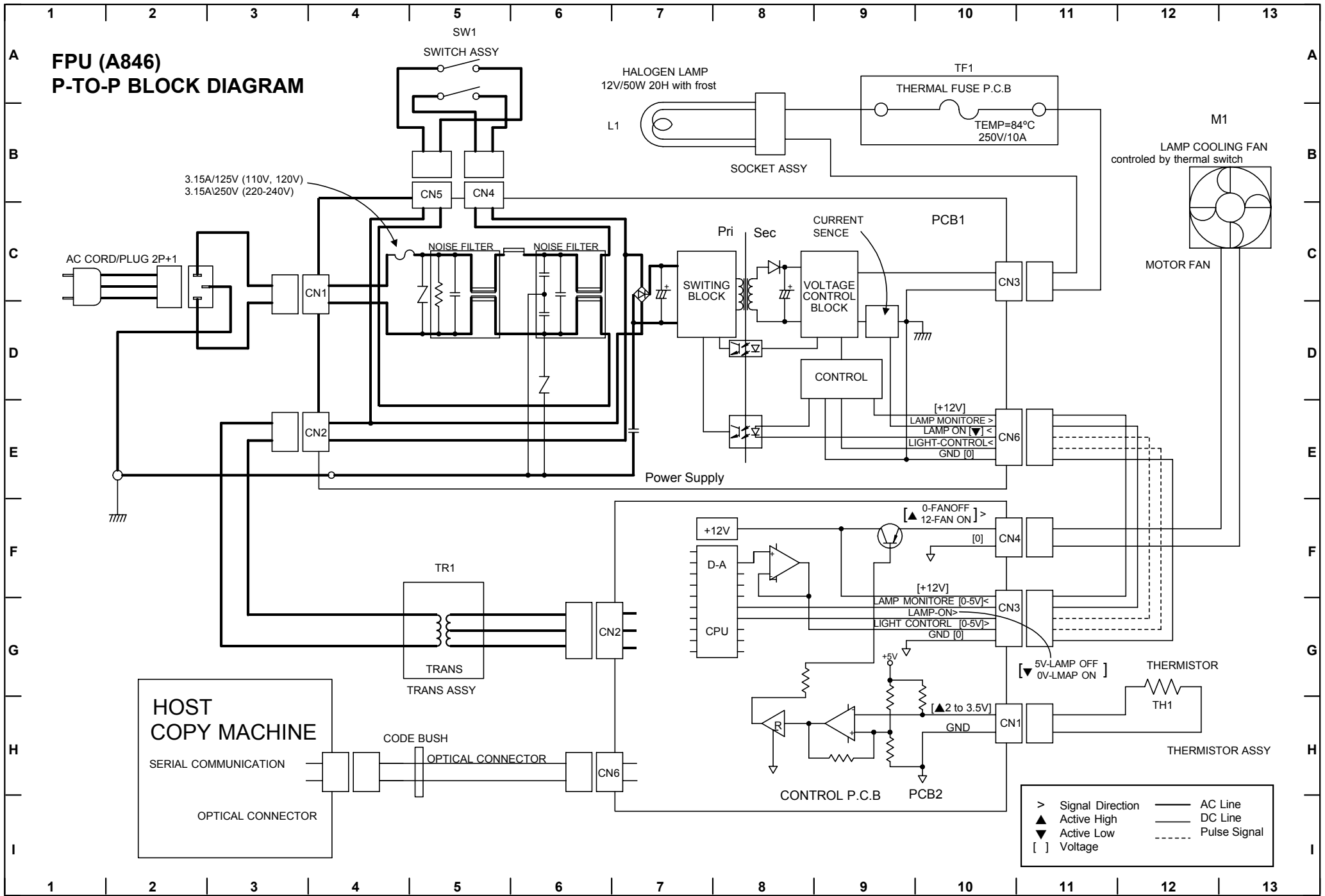

**FPU (A846)
P-TO-P BLOCK DIAGRAM**

3.15A/125V (110V, 120V)
3.15A/250V (220-240V)

HALOGEN LAMP
12V/50W 20H with frost

TF1
THERMAL FUSE P.C.B
TEMP=84°C
250V/10A

M1
LAMP COOLING FAN
controlled by thermal switch

PCB1
SWITCHING BLOCK
VOLTAGE CONTROL BLOCK
CURRENT SENCE
CONTROL

HOST COPY MACHINE
SERIAL COMMUNICATION
OPTICAL CONNECTOR

CONTROL P.C.B
CPU
D-A
+12V
+5V
GND
[▲2 to 3.5V]

- > Signal Direction
- ▲ Active High
- ▼ Active Low
- [] Voltage
- AC Line
- DC Line
- - - Pulse Signal

FILM PROJECTOR UNIT (A846) ELECTRICAL COMPONENTS

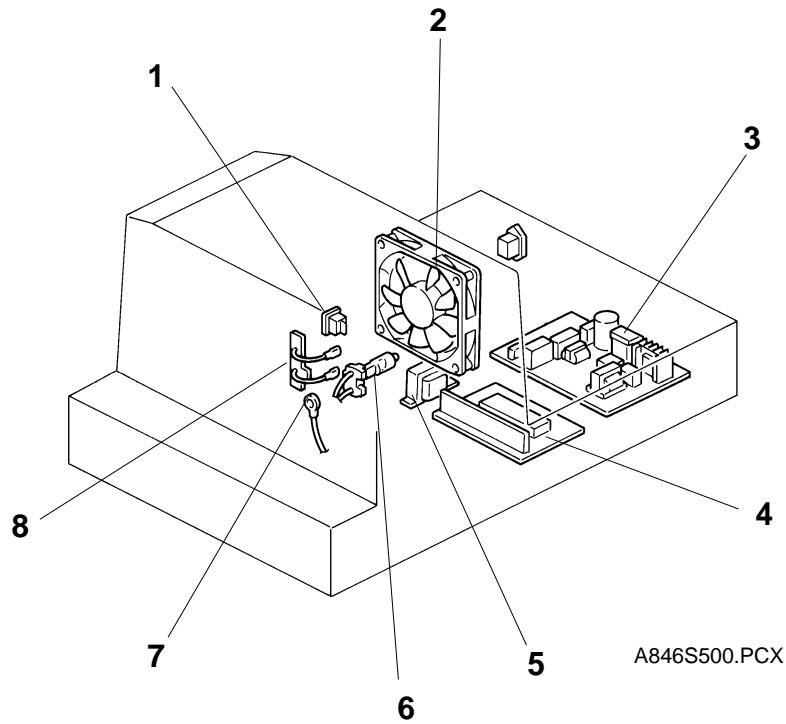

Index No.	Description	Symbol	P-to-P
1	Projector Switch	SW1	A5
2	Lamp Cooling Fan	M1	B13
3	Projector Lamp Regulator	PCB1	C10
4	Projector Control Board	PCB2	H10
5	Transformer	TR1	F5
6	Projector Lamp	L1	B7
7	Lamp Thermistor	TH1	G12
8	Lamp Thermofuse	HF1	B10